



KELSIUS

Laboratory

Wireless Temperature Monitoring and Digital Task Management

**PRIMARY
AUTHORITY**

Worcestershire
Regulatory Services

Supporting and protecting you



KELSIUS

Company Story

Kelsius are one of Europe's leading manufacturers and providers of Wireless Temperature Monitoring systems and Digital HACCP systems and we take pride in working with Worcestershire Regulatory Services in a Primary Authority Partnership.

Founded in 2003, Kelsius is a technology company that has a strong market presence in Ireland and the UK and exports their products and services to 47 countries across the globe.

Our customers range from pharmaceutical manufacturers, hospital pharmacies, laboratories and blood science departments, life science facilities and vaccination centres.

We are committed to continuous innovation and our systems utilise the latest technologies to provide peace of mind and easy-to-use systems to our customers.

Our customer support team offer unrivalled levels of service and can offer 365/24/7 support when required to global customers.



Our Mission:
To make the world
safer for consumers
of food and
medicine.

ISO9001:2015 Accredited

ISO14001:2015 Accredited

ISO 27001 compliance through our partners AWS

Kelsius system complies with FDA 21 CFR Part 11 regulations

Sustainability

Our Commitment

We are committed to improving global sustainability by focusing on 3 principals.

**Remove
Paper**

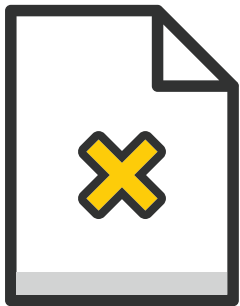

**Reduce
Waste**



**Protect
Stock**



By prioritising these principals, we aim to reduce global paper and stock waste through digitised and automated solutions.



Our Solutions

1. Reduce Waste:

Every year, billions of tonnes of waste directly contribute to generating high levels of greenhouse gas emission. The vast majority of this waste is due to lack of cold chain traceability or incorrect storage temperatures.

Reliable temperature monitoring ensures storage units and products are consistently kept at optimal temperatures removing the risk of stock being spoiled. This prevents large amounts of unnecessary waste.

2. Reduce Paper Usage, Paper Waste and Paper Storage:

The average small-medium business must have on average 10,000 sheets of paper available annually to conduct manual temperature monitoring, with each sheet taking 6-9 years to decompose.

Our Systems removes the need for manual paper records therefore significantly reducing a company's paper and ink cartridge waste.



Our Contribution

Our contribution and responsibility is to reduce emissions and environmental impact across our operations.

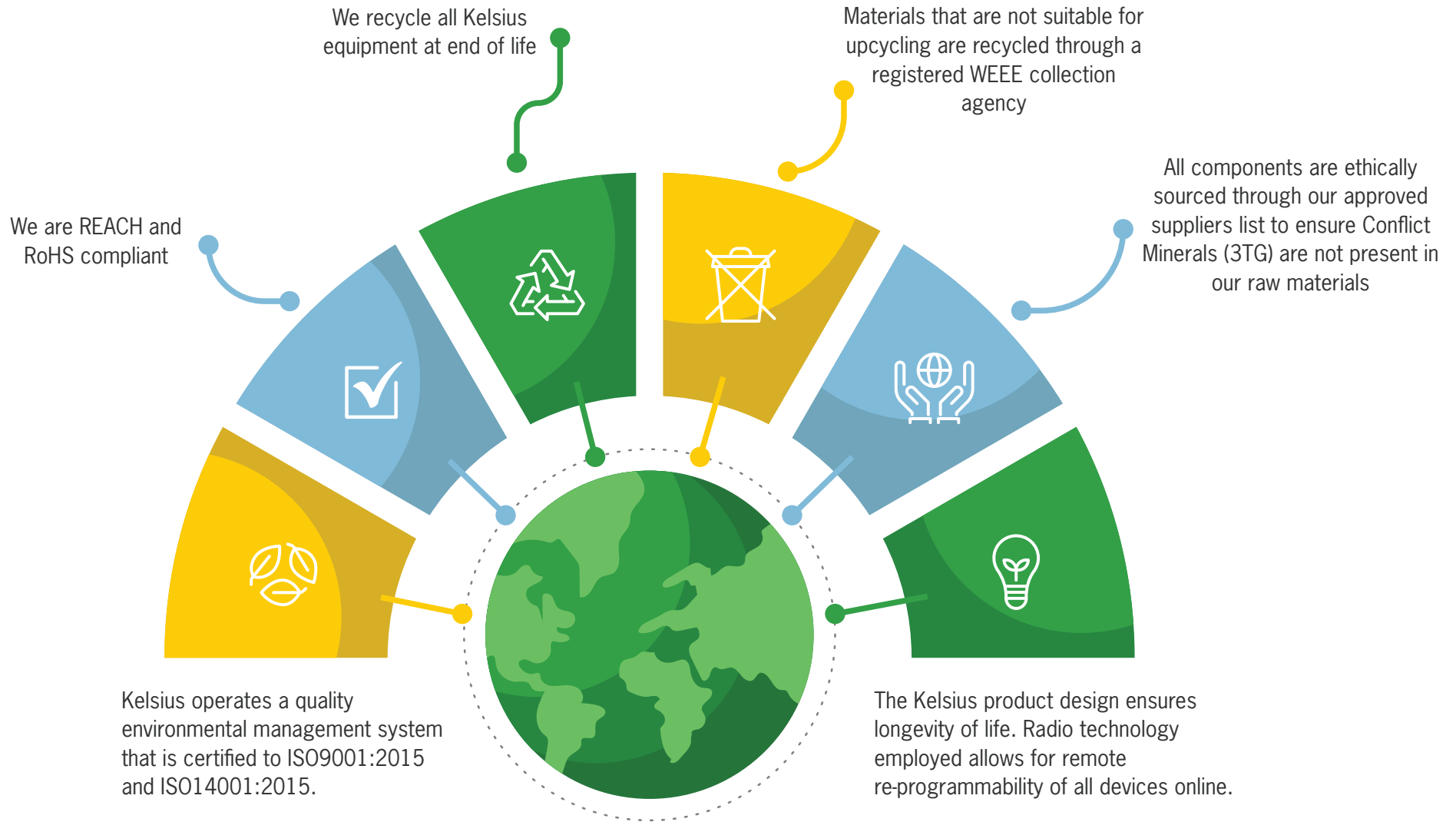

With the requirement to maintain records for up to 30 years, data storage is a large and important part of our business. We chose Amazon Web Services (AWS) as data storage partner as a result of AWS' focus on Sustainability.

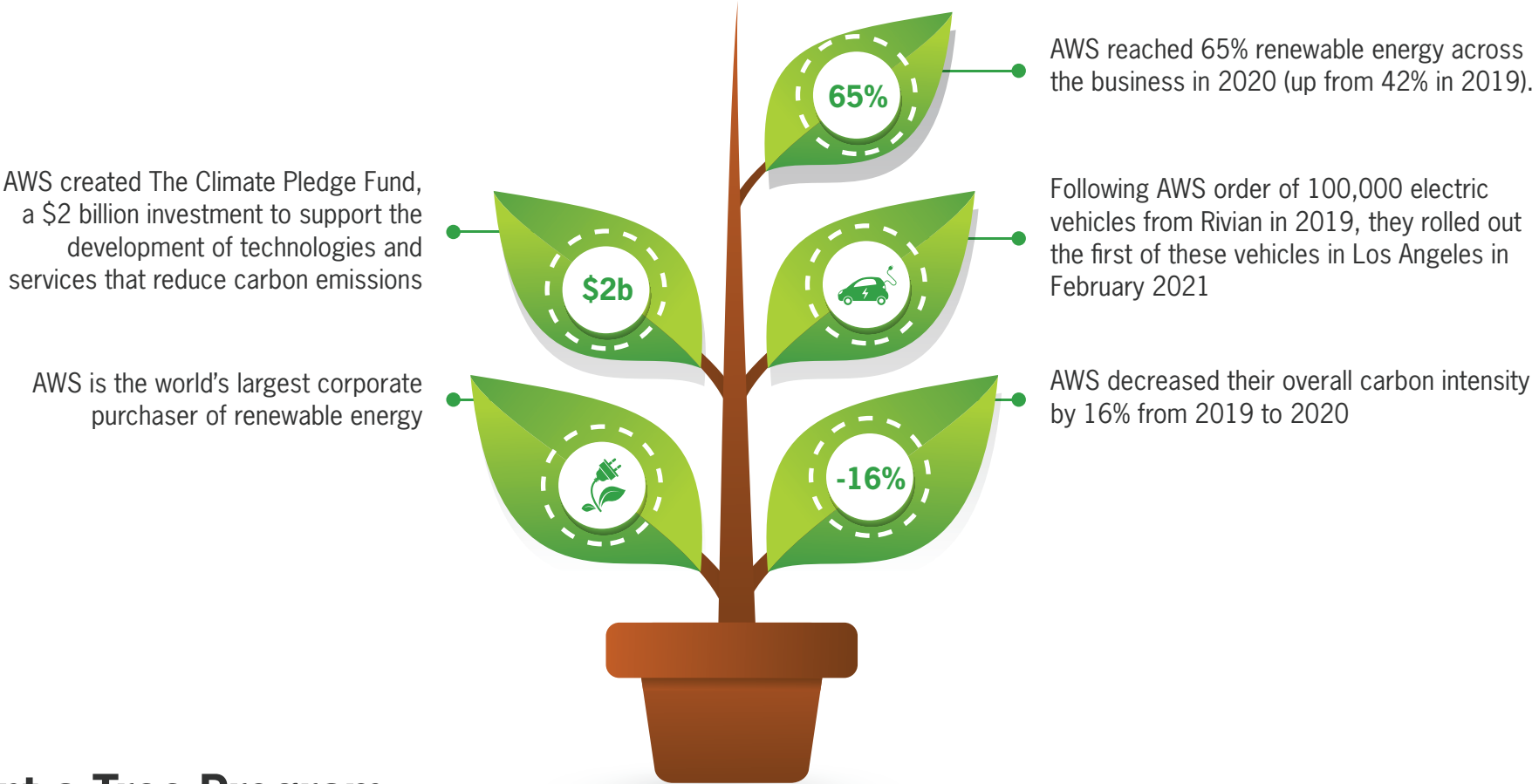

Plant a Tree Program

Reducing global paper usage and waste is one of our main objectives as a company and to enhance this, we have decided to plant a tree for every new customer that comes on board. Trees remove carbon dioxide from the atmosphere, produce oxygen and support the building of biodiversity, so together we will be directly contributing to improving the environment.

Security



Security & Compliance with Kelsius

Your Data and Privacy are Protected and Secured

Kelsius develop secure software design practices that include defining security requirements, threat modelling, code reviews, vulnerability management, incident resolution management and security testing. There are controls in place to validate/reject access to the customer portals including multi-factor authentication, roles and permissions.

- GDPR Compliant
- Data processed and stored in the EU
- Data encrypted at rest (data storage) and in transit (data transfer)

Information is readily available

Daily and incremental backups allow data to be restored to any 5-minute period between backups. Data archived for more than 13 months can be restored from the portal at any time for audits of historical data and there is data retention for 30+ years. There's also an automated disaster recovery plan in place to ensure maximum uptime across 3 geographically dispersed data centre locations within Ireland.

- 24/7/365
- Alerts via email/SMS/voice calls
- Self-healing data storage
- Automated crash recovery over multiple data centres



You are compliant

Kelsius complies with FDA 21 CFR Part 11 regulations – ISO 27001 compliance (AWS). A complete audit trail is available including user activity and change management audit records. There are multiple user roles to customise and control access to data and system configurations, and strong data governance where data is only accessible by the customer and a controlled small number of Kelsius employees.

Strong password policy is enforced and multifactor authentication is used to access the customer portal.

Industry Challenges

Clinical Laboratories are a highly regulated and complex environment that presents quality, compliance, supply chain, environmental and labour challenges on a daily basis.

Gaps in cold chain traceability can put patient safety at risk and lead to destruction of valuable samples and product.

Maintaining paper records means that Management and Technicians spend a lot of time on paperwork and manual temperature checks.

Manual Records are slow, time consuming and leave a large margin for error or issues to arise.

Manual Records are open to falsification, difficult to manage and access for auditing, and require costly storage for up to 30 years.

Missing records can lead to audit failure.

Temperature excursions on freezers and fridges can lead to spoiled samples.

Stock loss due to freezer/chill failures can lead to substantial financial loss.

Manual Monitoring can lead to gaps in Quality Control.

Undetected fridge/freezers breaking down or doors left open can lead to substantial loss of valuable product and samples.

Any of these serious failures can lead to claims of poor corporate governance and concerns for patient safety.



The Solution

CoolCheck ensures tamperproof, Automated Temperature Monitoring and by using the best available technology that delivers good corporate governance and improved risk mitigation.

CoolCheck ensures compliance with all Regulatory requirements and eliminates the risk of non-compliance.

CoolCheck closes any gaps in Cold Chain Traceability.

CoolCheck –ed √ app eliminates all paper from your daily operations removing the cost of paper, printing, ink cartridges, paper record storage and the staff time spent on filling in paper records, distributing and filing paper records.

The automated sensors record the temperature in each location every 5 minutes eliminating the need for manual temperature recording.

This can save valuable time for your key personnel depending on the size of your operation.

24/7 Automated SMS, email and telephone call alerts can be set

up to warn key staff members of temperature excursions, power outages or doors left open to avoid any expensive stock loss and disruption to operations.

Real time reporting gives management team visibility of all task completion, records, non-conformances and corrective actions as they happen.

Live and historical data available on your Kelsius Web Portal with automated PDF Reporting you helps and your team maintain quality, safety and operational efficiencies.

Management have much more control in the Process and can ensure greater Quality Control.

Key members of staff are freed up and can concentrate on other activities- increasing staff productivity.

A full range of Calibration Services are provided as required.



The CoolCheck Temperature Monitoring System:

- **Flexible & wireless** sensor network that supports both large and small environments.
- Easy-to-use, non-disruptive deployment—no need for expensive hard-wired infrastructure.
- Cost-effective, **automated record keeping** eliminates manual checks and records.
- Secure, centralised, encrypted data keeps your records safe.
- Global access to information when and where you need it— by sensor, by room, by facility.
- Real-time **alarming and alerting** for temperature compliance and product quality assurance.
- Improved **visibility and compliance** through online data history and audit trail.



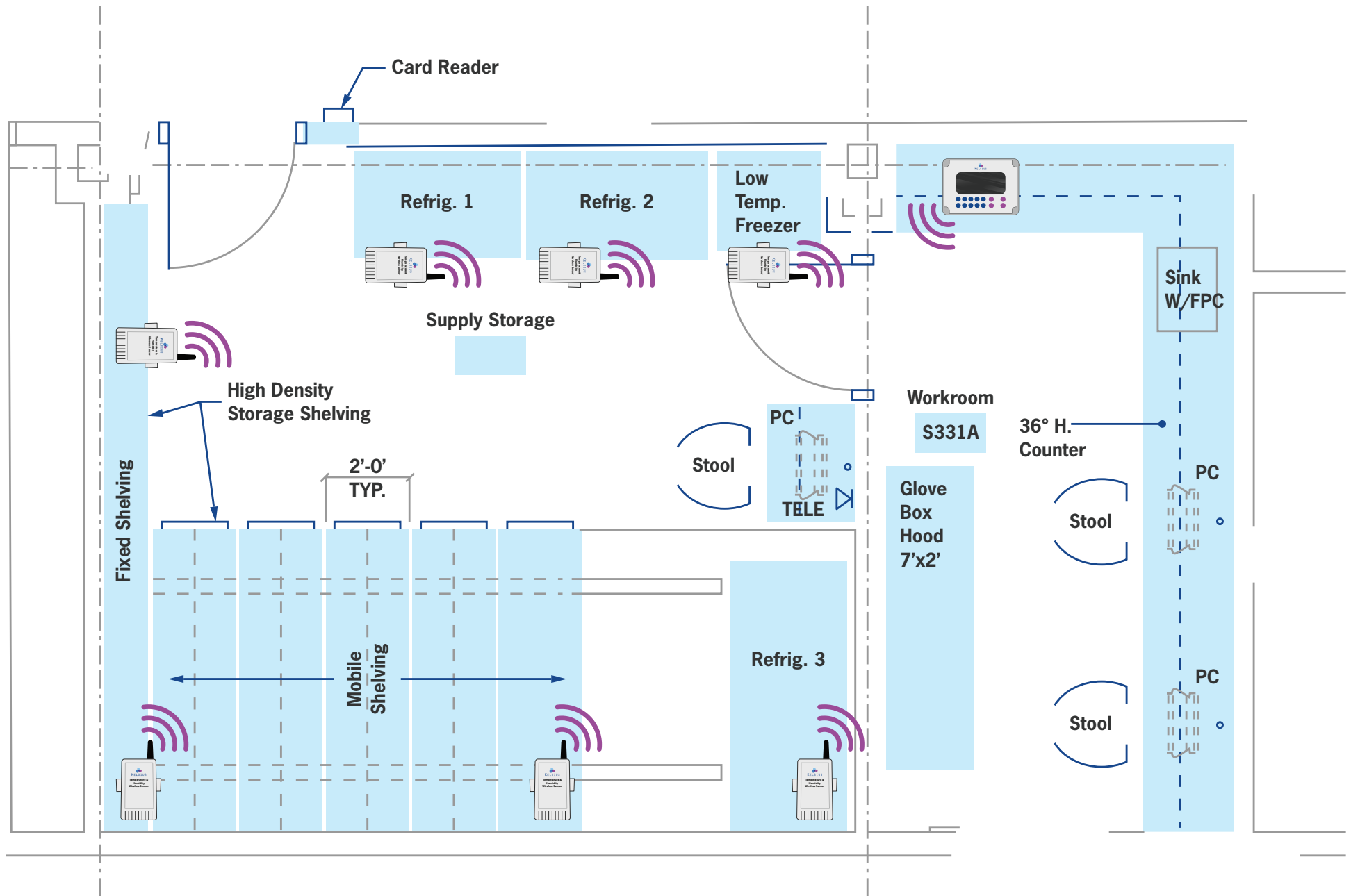

Wireless Temperature Sensor



Network Controller

CoolCheck Monitoring System at work:

CoolCheck is a fully integrated solution for facility temperature, humidity and condition monitoring which combines wireless sensors which are linked to their own network and web portal.

- CoolCheck wireless sensors are configured with user-defined alarm thresholds and measurement intervals. They are strategically placed inside any number of storage areas to record environmental conditions.
- CoolCheck wireless sensors record data and transmit the encrypted information wirelessly to a local Network Controller.
- The CoolCheck Network Controller relays the information to the Web Portal. All data is stored securely and is accessible to authorized users via a web browser; additional software is not required.

- The CoolCheck Web Portal provides immediate access to real-time and historical sensor data for all monitoring locations—and accessible from any web enabled device. Reports are available on demand or can be scheduled using a report wizard which will generate and distribute reports automatically via e-mail.
- When an excursion occurs, designated personnel can be alerted through audible/visual alarms, as well as through e-mail, text or automated phone call. Once a problem has been identified and corrective action has taken place, the incident can be recorded in the system's historical audit log.

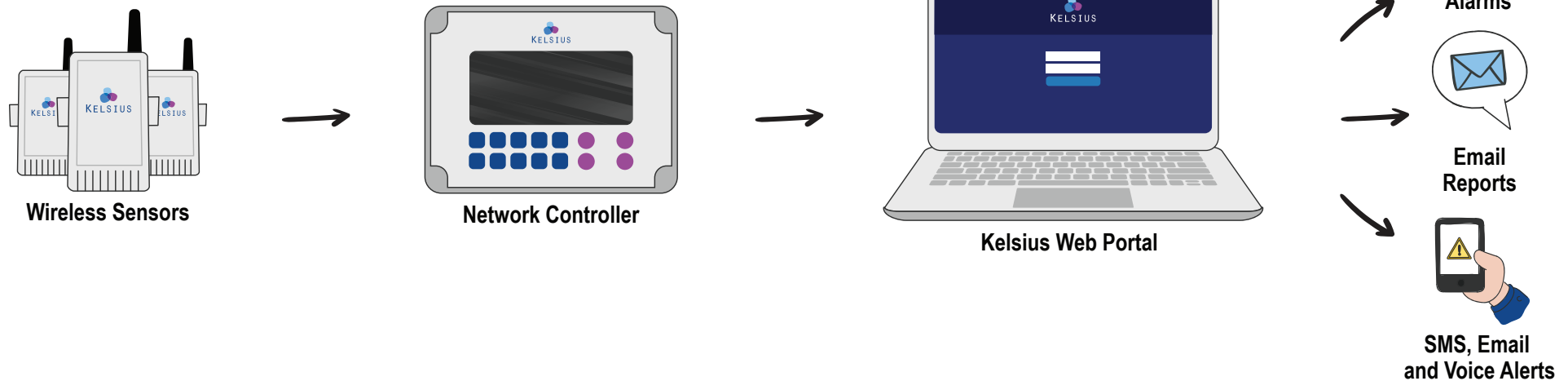

Your Data: Secure & at Your Fingertips

Humidity						
Sensor Name	Min.(%)	Max.(%)	Average(%)	Standard Deviation	Total Records	
Sensor 1 (Basement)	41.5	53.3	45.4	3.3	293	
Sensor 2 (Basement)	42.0	53.8	45.9	3.1	293	
Sensor 3 (Lab 1)	41.3	53.1	45.3	3.0	293	
Sensor 4 (Lab 2)	41.0	53.3	45.2	3.4	292	
Sensor 5 (Lab 3)	42.0	53.7	46.0	3.1	293	
Sensor 6 (Lab 4)	42	53.1	46	3.1	293	

Your Data: Secure & at Your Fingertips

- Dashboard
- Site Map
- Sensor Graphs
- Alert Events
- Report Wizard
- Documents and Manuals
- Configuration
- Audit Trail
- User Profile

Customer Notice
 Please note: Flashing icons representing outstanding Corrective Actions will appear in the device boxes below for a period of 7 days, after which the icon will no longer appear. All outstanding Corrective Actions are listed as normal in the Alert Events tab. We've introduced this change to greatly enhance the speed at which your Site Map loads

WARNING	Sensor has been above the Warning threshold for longer than the delay period
CRITICAL	Sensor has been above the Critical threshold for longer than the delay period
MAINTAIN	Sensor is in Maintain Mode. No alerts will be generated while the sensor is in this mode
ALARMOFF	Alarm has been turned off on this sensor
SERVICE	Sensor is in Service Mode. After the Service Timeout this sensor will return to Normal No alerts will be generated while in Service
MISREAD	Sensor has recorded a value which the system detects as a bad reading.
COMMFAIL	Communication with this sensor has failed
COMMISS	Temporary Communication failure with this sensor

Refrigerator 1

Sensor 1 1 A 5.0 °C	Sensor 2 1 P 5.3 °C	Sensor 3 2 A 4.9 °C	Sensor 14 2 P 4.9 °C	MainsPower ON	Repeater 1 11.5 V.	Repeater 2 11.2 V.
---------------------------	---------------------------	---------------------------	----------------------------	------------------	-----------------------	-----------------------

Refrigerator 2

MainsPower ON	Repeater 2 11.1 V.	Repeater 3 11.0 V.	Fridge 1 A 3.6 °C	Fridge 1 B 3.6 °C	Fridge 2 A 3.8 °C	Fridge 2 B 3.8 °C
------------------	-----------------------	-----------------------	----------------------	----------------------	----------------------	----------------------

Refrigerator 3

Fridge A 6.1 °C	Fridge B 6.3 °C	MainsPower ON	Fridge C 5.2 °C	Fridge D 5.1 °C	Short Stay Fridge A 3.8 °C	Short Stay Fridge B 3.9 °C
--------------------	--------------------	------------------	--------------------	--------------------	-------------------------------	-------------------------------

Low Freezer Temp

Fridge A 3.6 °C	Fridge B 3.6 °C	Freezer A -18.0 °C	Freezer B -18.0 °C	Fridge C 5.1 °C	Fridge D 5.6 °C	MainsPower ON	Fridge E 5.4 °C
--------------------	--------------------	-----------------------	-----------------------	--------------------	--------------------	------------------	--------------------

Your Data: Secure & at Your Fingertips

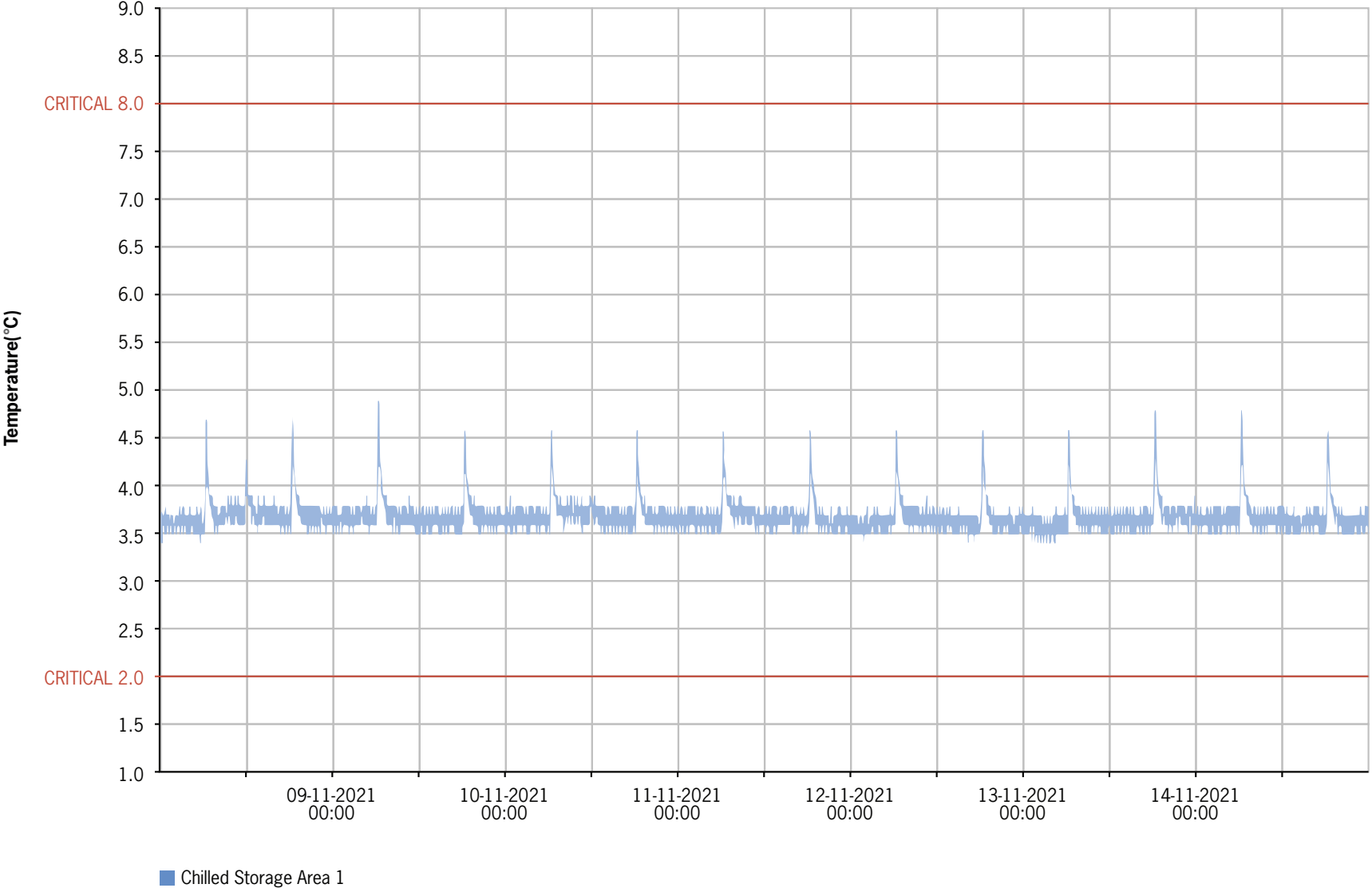

Your Data: Secure & at Your Fingertips

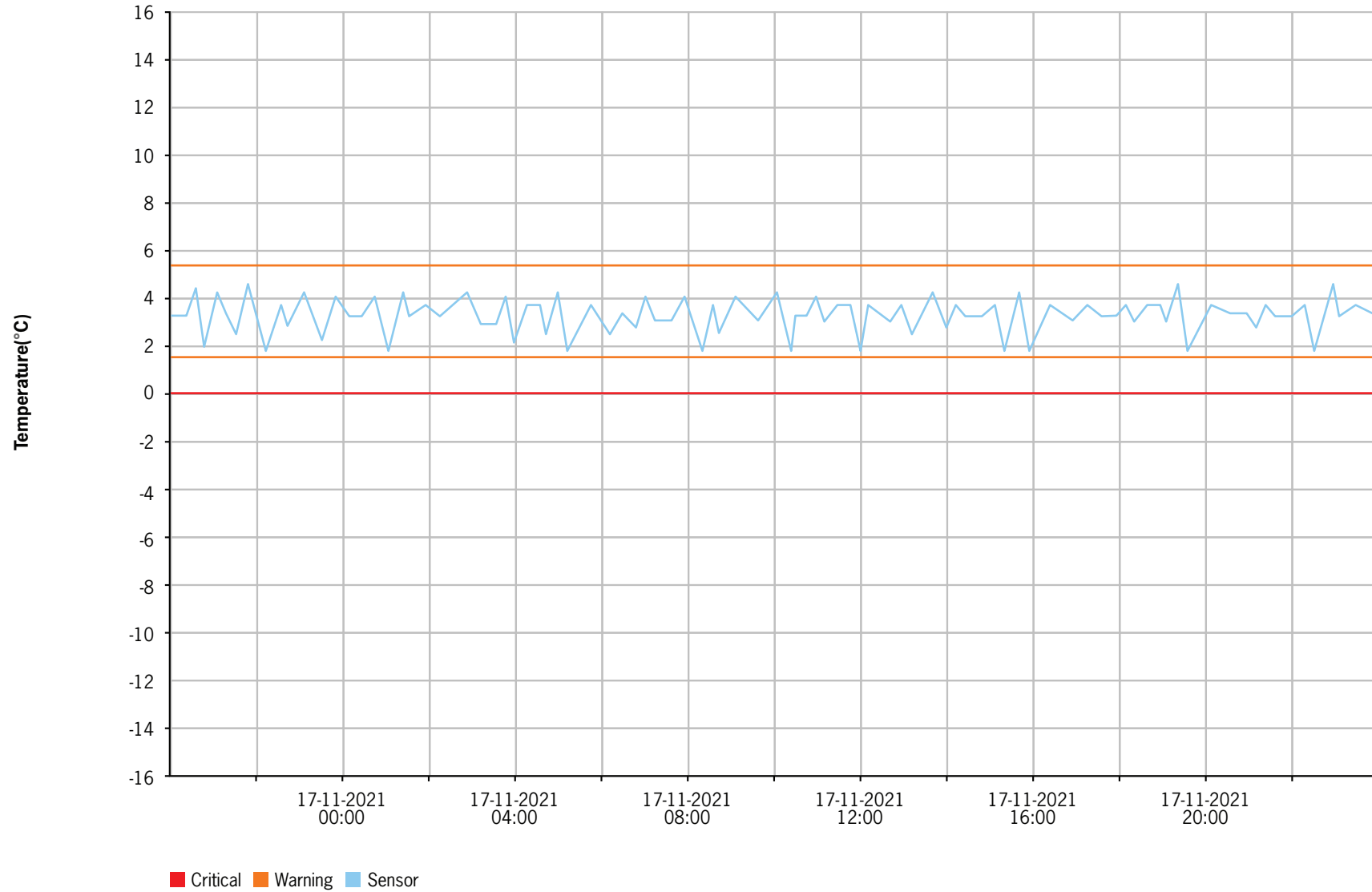

The CoolCheck Web Portal makes data access and reporting easy. The portal's dashboard and site map provide immediate access to key information regarding the current state of all monitored locations. The dashboard highlights current sensor alerts, while the site map provides a quick overview of all sensors, their current readings, and their current status (e.g., normal, warning, or critical).

Information is delivered in the format your organization prefers; data can be viewed on demand or downloaded in multiple formats (e.g., .pdf, .xls, .csv formats) for a given day, week, or specific time period. Reports can also be scheduled for automated daily/weekly electronic delivery through the Report Wizard.

Alarming and alerting capabilities are key features of the CoolCheck system. The system can alarm on sensor-level readings (i.e., temperature excursions) or system-level issues such as damage to or removal of sensors, power failure, device malfunction, and network connectivity loss.

Each alert can be configured to notify designated personnel through a variety of methods: local audible/visual alarm beacons, email message, text message, or automated phone call. full access to add corrective actions and sign-off data. In addition, all data transmissions are encrypted for security assurance.

- Audible/visual alarm beacons can be installed at various high-visibility points within the facility to alert on-site staff that an

excursion or system-level issue needs attention. Beacons can be configured to alarm for an individual sensor or group of sensors.

- E-mails and text message alerts can be configured to reach designated personnel with information that includes the exact location and details of the alarm. Escalating, automated phone calls can also be made to designated personnel until someone logs in, investigates the alarm, and takes action.

Corrective actions can be used to document your process controls. Once an excursion has occurred, corrective actions can be entered by authorized users. A user can select from a pre-defined list or can manually enter a corrective action as needed. Every corrective action entered is date and time stamped and includes electronic signatures.

Electronic record keeping helps to assure that you have a robust audit trail when needed. The CoolCheck system maintains a rigorous 21 CFR Part 11 compliant audit log, tracking user and system activities including configuration changes, user logins, alerts, and corrective actions.

Your data is secure using a variety of methods. Access is protected by username and password authentication. Depending on their responsibilities, personnel can be granted different levels of access including read-only, read/write or full access to add corrective actions and sign-off data. In addition, all data transmissions are encrypted for security assurance.

Kelsius Product Specification

Device Type	Temperature and Humidity Sensor		Temperature Sensor (Standard and Door Ajar version)	Bloodbank Sensor	Temperature Sensor with Probe	Network Controller
Product Code	K101SH		K101A & K101DA	K101BB	K101P	K106B
Unit	Temperature C	%RH	Temperature °C	Temperature C	Temperature C	na
Max	+40C	100%RH	+40°C	+40C	80C	na
Min	-35C	0%RH	0°C	-35C	0C	na
Accuracy	0.5C	5%RH	0.5°C	0.5C	0.5C	na
Resolution	0.1C	0.1%RH	0.1°C	0.1C	0.1C	na
Power	2 x 3.6V Lithium		2 x 3.6V Lithium	2 x 3.6V Lithium	2 x 3.6V Lithium	12VDC PSU with 6 x 1.2V NiCd Battery Bkup
Battery Life	up to 5 years		up to 5 years	up to 5 years	up to 5 years	na
Line of sight Range	100m		100m	100m	100m	600m

Kelsius Product Specification

Device Type	Amplified Repeater	RF Alarm	Alarm Flasher (plug-in)	Cryogenic Sensor (battery-op'd) - Unit only, add T'couple TC1	Cryogenic Sensor (Amplified) - Unit only, add T'couple TC1
Product Code	RP5	AL3	AL1	K105T	K105Amp
Unit	na	na	na	Temperature °C	Temperature °C
Max	na	na	na	+200°C	0°C
Min	na	na	na	-200°C	-200°C
Accuracy	na	na	na	0.5°C(>-100°C) / 1°C(<-100°C)	0.4°C(>-100°C) / 0.7°C(<-100°C)
Resolution	na	na	na	0.1°C	0.1°C
Power	12VDC PSU with 4 x 1.2V NiCd Battery Bkup	12VDC PSU with 4 x 1.2V NiCd Battery Bkup	9 to 12VDC (supplied by Net Controller)	2 x 1.5V C-Cell	12VDC PSU with 4 x 1.2V NiMH Battery Bkup
Battery Life	na	na	na	up to 6 months	na
Line of sight Range	600m	600m	na	100m	600m

Kelsius Product Specification

Device Type	CO2 Sensor		O2 Sensor		4-20mA Sensor
Product Code	K105-CO2		K105-O2		K420Amp
Unit	%CO2	Temperature °C	%O2	Temperature °C	mAmps
Max	10%	40°C	25%	40°C	20mA
Min	0%	5°C	0%	5°C	0mA
Accuracy	0.20%	0.5°C	0.20%	0.5°C	1% of reading
Resolution	0.10%	0.1°C	0.10%	0.1°C	0.1
Power	12VDC PSU with 4 x 1.2V NiCd Battery Bkup		12VDC PSU with 4 x 1.2V NiCd Battery Bkup		12VDC PSU with 4 x 1.2V NiCd Battery Bkup
Battery Life	na		na		na
Line of sight Range	100m		100m		600m





kelsius.com

Email sales@kelsius.com

Web www.kelsius.com

Call Ireland 074 91 62982

Call UK North 07879 437237

Call UK South 07803 520 140

Kelsius Ireland

Unit 2, Ballyconnell Industrial Estate,
Falcarragh, Co. Donegal, Ireland

Kelsius UK

124 City Road,
London,
EC1V 2NX



**PRIMARY
AUTHORITY**

Worcestershire
Regulatory Services

Supporting and protecting you